



One-Pipe Geothermal Design

Simplified GCHP System

By Kirk Mescher, P.E., Member ASHRAE

Classic designs of ground-coupled heat pump systems (GCHP) use two-pipe distribution networks with variable flow pumping and all of the ancillary water flow control devices. However, a one-pipe central distribution (distributed primary-secondary) loop is a simple system that can save first costs and operating costs. Series-connected heat pumps with a local circulator draw water from the one-pipe loop when their local thermostat calls for either heating or cooling.

Two Pipe Versus One Pipe

Figure 1 shows the standard approach to a building distribution network serving a GCHP system. The piping network delivers water to and returns water from heat pump units in either a direct or reverse return configuration. Loop pumps provide the necessary head and flow in response to system demand. Individual

heat pumps are equipped with motorized valves. These are interlocked with the compressor so that branch flow through the heat pump occurs only on a call for heating or cooling.

One-pipe distribution systems were common in hot water heating systems during the 1940s and 1950s. At that time, individual heating devices were

limited in size because, otherwise, the pressure drop of the overall system would be impractically high. Its modern incarnation, as slightly adapted and applied to GCHP systems, offers cost and efficiency benefits while preserving simplicity.

Figure 2 shows a GCHP one-pipe design. Zone heat pumps are connected to the primary pipe that serves as a supply and return. Flow to and from the primary piping is facilitated by small secondary circulators inside the cabinet of each heat pump unit. The flow through the well field and the primary pipe is provided through parallel central pumps.

The obvious question with this arrangement is, “Isn’t the water too hot when it gets to the last heat pump?”

About the Author

Kirk Mescher, P.E., is a principal at CM Engineering in Columbia, Mo.

The temperature increase or decrease through the loop field is a function of the flow rate in the primary pipe. The flow through the individual heat pumps is a function of the secondary circulator.

EER and COP

Ratings published by heat pump manufacturers are based on standardized conditions. Because heat pumps operate over a range of conditions throughout the year, evaluation at a single rating point is inappropriate when analyzing annual energy consumption. Unit EER and COP must be adjusted to reflect actual operating conditions. Most manufacturer-provided computerized equipment selection programs properly account for fan and pump power in their ratings. However, some programs and catalog information do not make this adjustment. *Table 1* shows the differences.

To get a full map of system performance and the overall values of COP and EER, one must know the temperatures of the entering water and the duration of that temperature, along with the space load conditions, over the full annual cycle of 8,760 hours of operation.

Other issues exist with ARI/ISO-rated EERs and COPs. The ISO standard for rating water-source heat pumps includes the necessary energy required to move the water *through the machine*. The energy necessary to move water through a loop field, the distribution network and hydronic devices such as strainers, flow control valves, balancing valves and so forth, is not included in unit test ratings. These additional losses should be evaluated in the overall hydronic system design. The operating system fan static pressure during the rating test is 0.0 in. w.g. (0 kPa) to get an overall system COP or EER rating, the additional energy requirements for pumping and air movement must be added to the base rating point.¹

Loop Pumping in GCHP

In most GCHP systems, fluid circulation represents significant energy consumption. Excessive system pressure, flow rates and long operational times result in poor energy efficiency. Systems with excessive pumping energy will exhibit poor annual energy consumption performance.

Variable speed pump control is seen as a way to make pumping energy demand oriented to improve system efficiency. Stan-

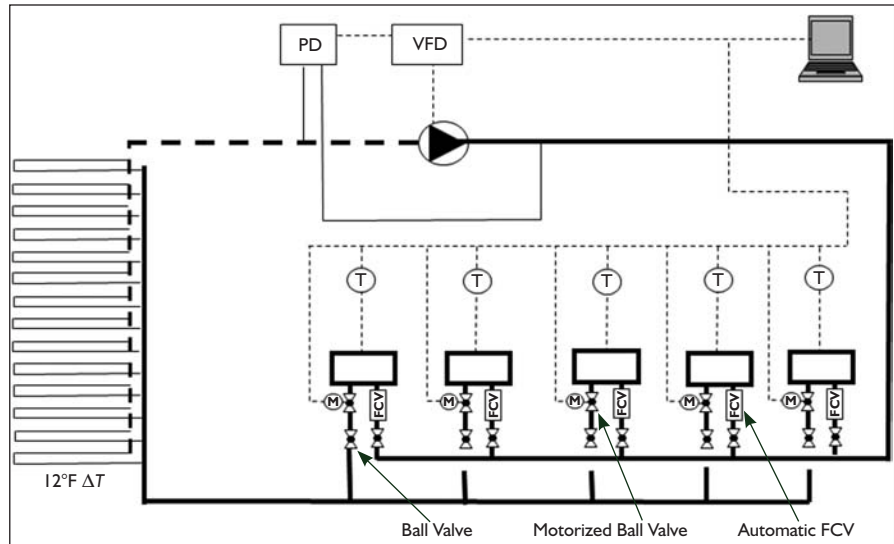

Figure 1: Basic two-pipe variable flow configuration with direct digital controls.

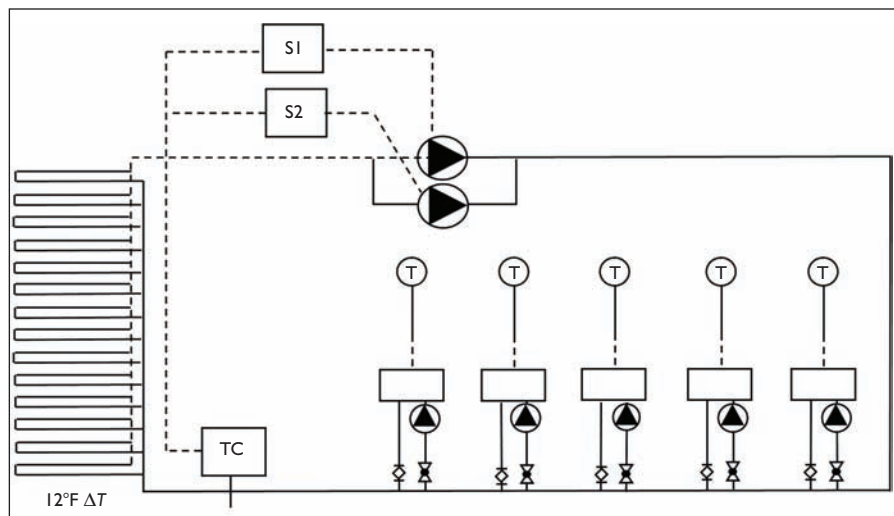

Figure 2: One-pipe system.

dard 90.1 includes design parameters for system horsepower and pump control.^{1,2}

Centrally pumped systems are sized to provide the necessary distribution pressure to match the maximum pressure requirement of a single unit. This often results in excessive pressure throughout the system that is turned into heat by flow regulation valves. In theory, variable flow operation offers a clear advantage over constant flow in terms of annual energy savings.

A pumping system that precisely matches individual unit pumping requirements and eliminates the overpressure (control setpoint and excessive supply pressure to a single unit) results in maximum pumping efficiency.

Current benchmarks for distribution loop pumping power in vertical closed-loop systems (two-pipe design) call for a target of 7.5 hp per 100 tons (5.6 kW per 352 kW) of peak block cooling load.² Because the head loss through a one-pipe network is low, primary pumping requirements often are held to less than 2 hp/100 tons (1.5 kW/352 kW).

Variable Flow System EER								
Cooling Capacity (TC)	Unit EER	Fluid EWT	Adjusted TC	Unit Watts	Fan Watts	Pump ^{*, †} Watts	Total Watts	System EER
30.7	26.7	30	29.7	1150	287	195	1632	18.2
33.7	26.9	40	32.7	1253	287	195	1735	18.9
36.4	26.5	50	35.4	1374	287	195	1856	19.1
36.2	24.2	60	35.2	1496	287	195	1978	17.8
36.7	22.3	70	35.7	1646	287	195	2128	16.8
35.8	19.8	80	34.8	1808	287	195	2290	15.2
33.7	16.9	90	32.7	1994	287	195	2476	13.2
32.7	14.8	100	31.7	2209	287	195	2691	11.8
29.8	12	110	28.8	2483	287	195	2965	9.7
27.6	10.1	120	26.6	2733	287	195	3215	8.3

Variable Flow System COP								
Heating Capacity (TH)	Unit COP	Fluid EWT	Adjusted TH	Unit Watts	Fan Watts	Pump ^{*, †} Watts	Total Watts	System COP
24.1	3.76	30	25.1	1878	287	195	2360	3.1
28.0	4.28	40	29.0	1917	287	195	2399	3.5
31.6	4.72	50	32.6	1962	287	195	2444	3.9
35.5	5.18	60	36.5	2008	287	195	2490	4.3
39.6	5.63	70	40.6	2061	287	195	2543	4.7
43.0	5.97	80	44.0	2110	287	195	2592	5.0
46.6	6.31	90	47.6	2164	287	195	2646	5.3

Assumptions: Air cfm/ton = 400; Static pressure = 0.5; Fan efficiency = 50%; Motor efficiency = 80%; gpm/ton = 2.5; Total dynamic head = 65; Pump efficiency = 60%; Motor and drive efficiency = 90%.

* Pump power is increased to compensate for flow control valve, motorized valve and strainer.

† 10 ft (28 980 Pa) is added to the system head to accommodate unit pressure drop variation and pressure control setpoint.

Table 1: Heat pump system EER and COP calculations.

Basic High-Efficiency Designs

GCHP systems operate at their greatest efficiency when unitary equipment is used within the system,² i.e., individual ground loops and circulators for each heat pump (Figure 3) and subcentral header/piping systems. In these arrangements, the building is broken down into smaller loops serving several heat pumps (Figure 4). Kavanaugh, et al.,² have promoted these concepts for a number of years with limited traction.

These strategies reduce inside loop piping cost and pumping horsepower.

However, no diversity connection exists that allows systems in the same building to share capacity. Each system must be individually designed and sized. Fully eliminating the building circulation piping reduces the inside piping and circulation pumping cost. However, the well drilling cost is increased.

Adding more bores around the building perimeter is sometimes a problem in terms of construction sequencing and installed cost.

Pumping Watts Input/ton	Pumping hp/100 tons	Grade	Allowable Pump Head (ft) With 60% Efficiency Pump	
			Minimum	Maximum
50 or Less	5 or less	A-Excellent	-	47.5
50-75	5-7.5	B-Good	47.5	71.3
75-100	7.5-10	C-Mediocre	71.3	95.0
100-150	10-15	D-Poor	95.0	142.6
>150	>15	F-Bad	142.6	-

Pump heads are calculated at 2.5 gpm/ton. For 3 gpm/ton (0.15 L/s·kW for 0.18 L/s·kW) reduce values by 17%.

Table 2: Pumping power benchmarks.²

Subcentral GCHP systems suffer from pumping complexity. Flow throughout the system is variable depending on the number of units in operation. The power requirements at each circulator must be evaluated when the system is in full operation. The pumps installed within these systems often have low flow and high head performance requirements. When individual pumps are in operation, the flow through the individual heat pumps is significantly beyond design needs,

therefore, wasting pump energy. Wire-to-water overall efficiency in these small circulators is often in the range of 20%. The increased power required at each heat pump results in diminished system EER and COP.

A one-pipe distribution system with constant circulation avoids the limitations of the subcentral GCHP systems.

One-Pipe Advantages

Reduced First Cost

In a two-pipe network system, additional pipe and pipe fittings are required over the one-pipe arrangement. Multiple one-pipe installations in schools and office buildings have shown a piping installation cost savings of \$0.50 to \$1.50/ft² (\$5.38 to \$16.15/m²). These systems are in the range of 50 to 200 tons (176 to 703 kW) and are located in Illinois. Cost savings are due to the installation efficiency associated with the coupled piping system and the design simplicity. Few piping size reductions are required. No flow control valves are needed, and there are low water

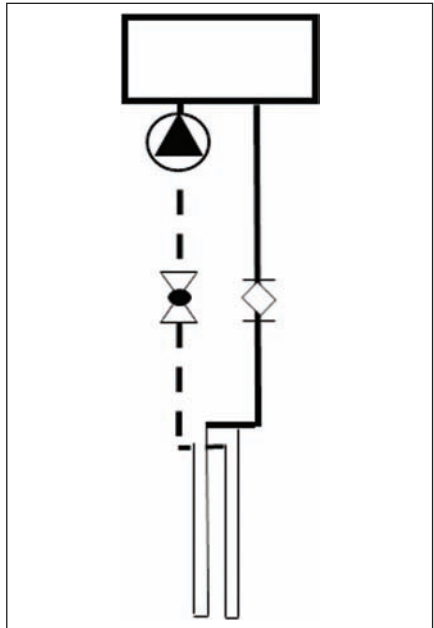

Figure 3: Simple GCHP.

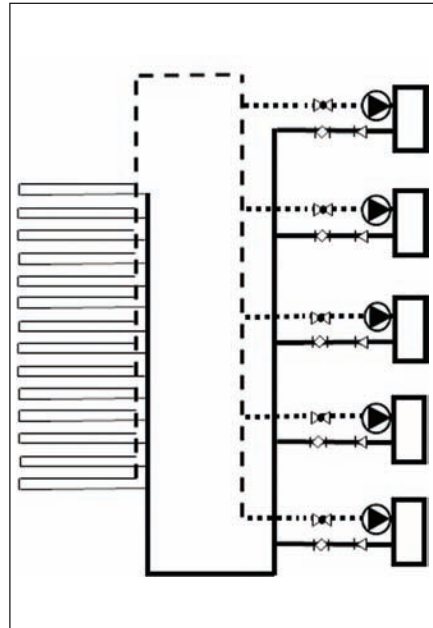

Figure 4: Subcentral GCHP.

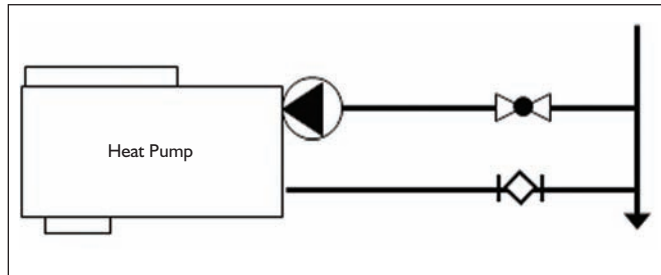

Figure 5: One-pipe connection diagram.

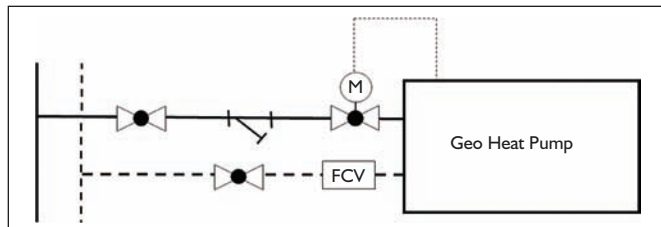

Figure 6: Two-pipe variable flow heat pump connection diagram.

Advertisement formerly in this space.

balance requirements. The pipe insulation has reduced fitting and valve cover requirements.

An additional, albeit less dramatic benefit, is the flexibility of locating the pumps anywhere within the system. Since the piping distribution is a single loop, pump location becomes irrelevant; locating pumps at the beginning of the piping network is no longer required. This offers flexible installation options that may be necessary in retrofit applications.

Simplicity

In a one-pipe system (Figure 2), the main loop flow is provided by a pair of parallel flow pumps. These pumps are alternated

Percent Load on System	10*	20*	30	40	50	60	70	80	90	100
Ground Loop Pressure Loss (ft)	1.8	1.8	1.8	3.2	5	7.2	9.8	12.8	16.2	20
Building Dist. Head Loss (ft)	1.35	1.35	1.35	2.4	3.75	5.4	7.35	9.6	12.15	15
Equipment Head (ft)	36.93	36.93	36.93	36.93	36.93	36.93	36.93	36.93	36.93	36.93
Addition for Control Setpoint	5	5	5	5	5	5	5	5	5	5
Total Pump Head (ft)	45.08	45.08	45.08	47.53	50.68	54.53	59.08	64.33	70.28	76.93
Flow (gpm)	54.3	54.3	54.3	72.4	90.5	108.6	126.7	144.8	162.9	181
Calculated Pump (hp) (100%)	0.5	0.5	0.6	0.9	1.2	1.5	1.9	2.4	2.9	3.5
Percent Loaded	17.6%	17.6%	17.6%	24.7%	32.9%	42.5%	53.8%	66.9%	82.2%	100.0%
Calculated Pump Efficiency	42.9%	42.9%	42.9%	50.7%	56.2%	59.4%	60.9%	62.0%	64.3%	65.0%
Pump Mech. (hp)	1.4	1.4	1.4	1.7	2.1	2.5	3.1	3.8	4.5	5.4
Selected Pump (hp)	6	–	–	–	–	–	–	–	–	–
Percent Load on Motor	24.0%	24.0%	24.0%	28.6%	34.3%	41.9%	51.8%	63.3%	74.9%	90.2%
VFD and Motor Efficiency	38.8%	38.8%	38.8%	38.8%	49.2%	60.8%	72.6%	82.2%	88.4%	92.1%
Pump Elect. (hp)	3.7	3.7	3.7	4.4	4.2	4.1	4.3	4.6	5.1	5.9
Power Consumption (kW)	2.8	2.8	2.8	3.3	3.1	3.1	3.2	3.4	3.8	4.4

*System power is limited to a 30% flow minimum.

Table 3: Variable flow calculations.

Equipment Head Loss Calculations (VFD)	
Item	Pressure Drop (ft)
Unit Pressure Drop (ft)	21*
Flow Control Valve (ft)	6.93†
Strainer (ft)	5
Isolation Valves (ft)	2
Connection Piping (ft)	2
Total Head Pressure (ft)	36.93

* Must have this pressure available throughout the system.

† 3 psi (21 kPa) used in calculation.

Table 4: Variable flow equipment branch head loss.

with use. Generally, a single pump provides the flow necessary to operate the system. The second pump is activated only when the system water temperatures are such that the system would benefit from additional flow.

While the flow through the overall system is managed at the primary pumps, the flow to each unit is served by a small wet rotor circulator within each unit (Figure 5). These small pumps have been the basis of all residential closed loop systems from the inception of the technology. The pump is called into operation when the compressor operates in a specific unit.

Central system water balance can be executed once and will stay constant throughout all operating modes. The secondary connection of the heat pumps ensures that there is no water flow variation at any device. Every heat pump has adequate flow regardless of how many units are in operation.

Two-pipe variable flow systems require flow control complexity, because the system changes with the operation of each unit.

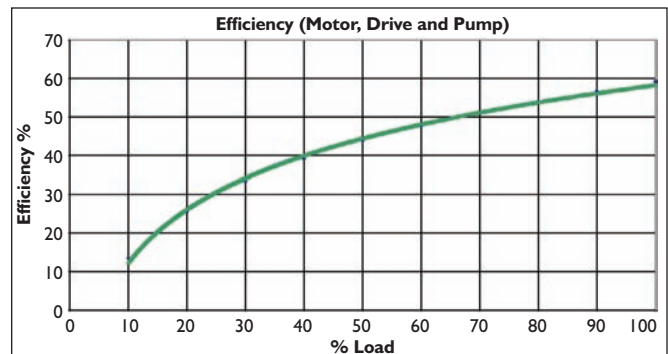

Figure 7: 25 hp inverter efficiency with load.^{3,4}

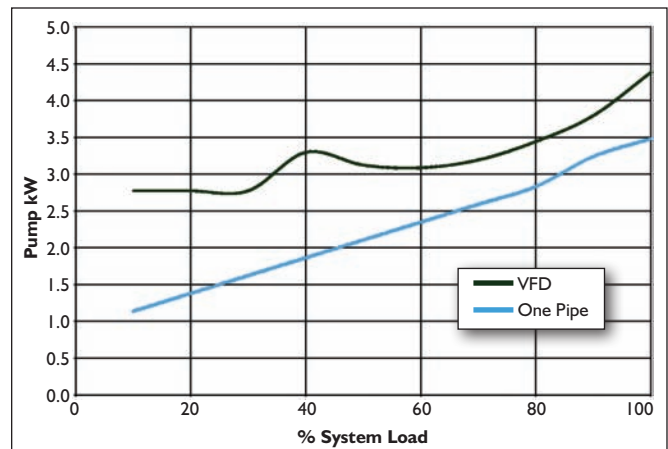

Figure 8: Variable flow versus one-pipe pumping system curves.⁴

Typical solutions to the system variation include the incorporation of motorized isolation valves, flow control valves, strainers, inverters and differential pressure controls (Figure 6).

Percent Load on System	10	20	30	40	50	60	70	80	90	100
Ground Loop Pressure Loss (ft)	11.25	11.25	11.25	11.25	11.25	11.25	11.25	11.25	20	20
Building Dist. Head Loss (ft)	8.4	8.4	8.4	8.4	8.4	8.4	8.4	8.4	15.0	15.0
Total Pump Head (ft)	19.7	19.7	19.7	19.7	19.7	19.7	19.7	19.7	35.0	35.0
Flow (gpm)	135.8	135.8	135.8	135.8	135.8	135.8	135.8	135.8	181.0	181.0
Calculated Pump (hp)	2.7	–	–	–	–	–	–	–	–	–
Selected Pump (hp)	1.5	(Two Required)	–	–	–	–	–	–	–	–
Pump Power at Condition (kW)	1.2	1.2	1.2	1.2	1.2	1.2	1.2	1.2	2.8	2.8
Percent Loaded	79.8%	79.8%	79.8%	79.8%	79.8%	79.8%	79.8%	79.8%	94.5%	94.5%
Power Consumption (kW)	0.9	0.9	0.9	0.9	0.9	0.9	0.9	0.9	1.1	1.1
Circulator Power (kW)	0.2	0.5	0.7	1.0	1.2	1.5	1.7	1.9	2.2	2.4
Total Pumping Power (kW)	1.14	1.38	1.62	1.86	2.11	2.35	2.59	2.83	3.24	3.48

Table 5: One-pipe system energy use.

Comparing One Pipe to Conventional Variable Flow

Table 3 summarizes a typical two-pipe GCHP system with central pumping and variable flow. The system has minimum static head of 33 ft (96 kPa), total head requirement of 68 ft (197 kPa) and a flow requirement for 181 gpm (11 L/s). This would be construed as an “on target” energy-efficient system that is using approximately 7.5 hp/100 tons (5.6 kW/352 kW) of cooling.² The inverter and motor

Advertisement formerly in this space.

Item	Pressure Drop (ft)
Unit Pressure Drop (ft)	11.2*
Isolation Valves (ft)	2
Connection Piping (ft)	1
Circulator Total Head (ft)	14.2

* Varies from 21 to 4.9. Average pressure loss is represented.

Table 6: One-pipe equipment branch head loss.

combination at the design conditions must be selected at 6 hp (4.5 kW) (two at 3 hp [two at 2.2 kW] pumps), which places the operating condition at 88% loaded. It is not unusual for pumps to be oversized by 25% to keep pump motors from overloading when operated individually (if they were selected to operate in parallel).

During building warm-up, the pumping system must be capable of providing adequate flow to every heat pump on the network (greater flow capacity required). Once the system drops below 40% loaded, the combined drive efficiency is reduced to under 50%. In most commercial applications, during unoccupied times, drives spend nearly 15 hours a day at low load conditions. The inverter and motor, while running unloaded, are consuming more power than they should, and the efficiency of the GCHP system is adversely affected.

Taking Advantage of the Law

Pump laws dictate that the head in a fixed hydraulic system varies with the square of the flow variation.

$$(Q_1/Q_2)^2 \text{ proportional to } H_1/H_2 \quad (1)$$

$$(Q_2/Q_1)^2 \times H_1 = H_2 \quad (2)$$

In a one-pipe configuration, the flow through the main distribution loop is independent of the number of units in operation. Therefore, while the system load is under 80% of the overall

Cooling Capacity (TC)	Unit EER	Fluid EWT	Adjusted TC	Unit Watts	Fan Watts	Pump* Watts	Total Watts	System EER
30.7	26.7	30	29.7	1,150	287	107	1,543	19.3
33.7	26.9	40	32.7	1,253	287	107	1,646	19.9
36.4	26.5	50	35.4	1,374	287	107	1,767	20.0
36.2	24.2	60	35.2	1,496	287	107	1,889	18.6
36.7	22.3	70	35.7	1,646	287	107	2,039	17.5
35.8	19.8	80	34.8	1,808	287	107	2,202	15.8
33.7	16.9	90	32.7	1,994	287	107	2,388	13.7
32.7	14.8	100	31.7	2,209	287	107	2,603	12.2
29.8	12	110	28.8	2,483	287	107	2,877	10.0
27.6	10.1	120	26.6	2,733	287	107	3,126	8.5

Heating Capacity (TH)	Unit COP	Fluid EWT	Adjusted TH	Unit Watts	Fan Watts	Pump* Watts	Total Watts	System COP
24.1	3.76	30	25.1	1,878	287	107	2,272	3.2
28.0	4.28	40	29.0	1,917	287	107	2,310	3.7
31.6	4.72	50	32.6	1,962	287	107	2,355	4.1
35.5	5.18	60	36.5	2,008	287	107	2,402	4.5
39.6	5.63	70	40.6	2,061	287	107	2,454	4.8
43.0	5.97	80	44.0	2,110	287	107	2,504	5.1
46.6	6.31	90	47.6	2,164	287	107	2,557	5.5

Assumptions: Air cfm/ton = 400; Static pressure = 0.5; Fan efficiency = 50%; Motor efficiency = 80%; gpm/ton = 2.5; Total dynamic head = 40; Pump efficiency = 60%; Motor and drive efficiency = 90%.

* Branch pump watts included in heat pump EER and COP rating.

Note: Temperature change and total heat are adjusted based on the fan static pressure of 0.5 in. w.c. (1245 Pa).

Table 7: One-pipe system EER and COP calculations.

flow requirement, a single pump meets the duty when operating constantly at 64% of the head and 51% of the power.

Above that load, the second central pump is placed into constant-speed operation. The circulating pumps at each unit are operated only when there is a heating or cooling load. Because there are a number of these pumps within the system, the individual unit flow requirements result in a linear energy consumption curve for the system (Figure 8).

For this comparison, the head loss through the well field at design conditions was assumed to be equal for both systems. Within the building, the head loss through the distribution loop is assumed to be 15 ft (44 kPa) at design for the two-pipe system and 10 ft (29 kPa) for the one pipe. The 5 ft (14 kPa) additional pressure for the two-pipe system

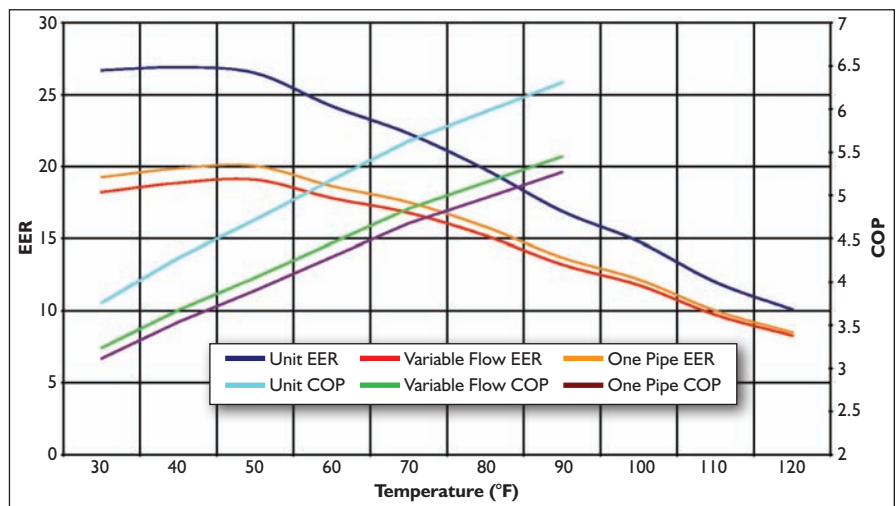

Figure 9: Heat pump system performance.⁵

comes from the additional piping and pipe fittings required for the distribution

network. Branch flow control equipment is fixed per Table 4.

By correlating the design elements presented in *Table 3* with *Figure 7*, an overall pumping efficiency comparison is presented in *Figure 8*. The energy consumption of either system is portrayed in kW.

Because most office and school buildings spend 14 to 15 hours per day in the unoccupied mode, the energy savings is substantial for the one-pipe design. The disparity in the curves arises from a combination of the part-load performance of the variable speed pumping system and the reduced head losses associated with the one-pipe system. Efficient off-peak performance is key to reducing annual energy use.

Cost and kBtu/ft ² (August 2007–July 2008)					
School	ft ²	Cost/ft ²	Total kBtu	kBtu/ft ²	ENERGY STAR Rating
Brigham	55,136	\$0.750	2,414,392	43.8	97
Fairview	37,436	\$0.969	1,121,141	29.9	94
Glenn	23,677	\$0.964	739,235	31.2	96
Hudson	31,000	\$1.036	1,056,555	34.1	90
Oakdale	43,212	\$1.038	1,433,521	33.2	94

Table 8: ENERGY STAR performance.

Loop Temperature and Heat Pump Performance

Heat pump performance was initially questioned because of the temperature rise in the one-pipe distribution loop. At peak design conditions, heat pumps operating within a one-pipe system are less efficient than traditional variable flow systems. However, with modern high efficiency heat pumps, the effect of temperature on performance is less pronounced than on previous equipment.⁵

The system EER and COP performance of a two-pipe variable flow system versus a one-pipe system is comparable. For example, in a two-pipe system at an 85°F (29°C) entering temperature, the equipment EER is 14.0. For the one-pipe solution, the average EER-based on a higher average entering water temperature of 91°F (33°C) (one-half of the loop water temperature difference), is an identical 14.0. In heating, the effect of the varying water temperature is greatly reduced because the COP is less temperature dependent as indicated in *Figure 9*.

Peak load efficiency calculations are a small part of the overall annual energy consumption. Peak loads (>80% of total capacity) occur for only 35 hours during the cooling season, and another 35 hours during the heating season. For the other 8,690 hours every year, the system operates at part-load conditions. So, when analyzing overall system efficiency, one must understand how the system responds during part load and how long the system may dwell at that condition.

At part load, space-by-space load variations are absorbed within the one-pipe loop as the connecting fluid is circulated. The temperature in the loop rises and falls as each unit is heating or cooling. This push/pull effect improves the overall operating efficiency.

GCHP systems have varying entering water temperature conditions depending on the time of the season, the previous loads imposed on the well field, etc. The operational comparisons presented in *Figures 10a* and *10b*, indicate the performance of GCHP systems, based on the fraction of system load (capacity). *Figure 10b* exhibits a profile similar to electric utility load factor relationships.

Typical school HVAC systems are less than 60% loaded for more than 78% of the operational hours. During part load, the

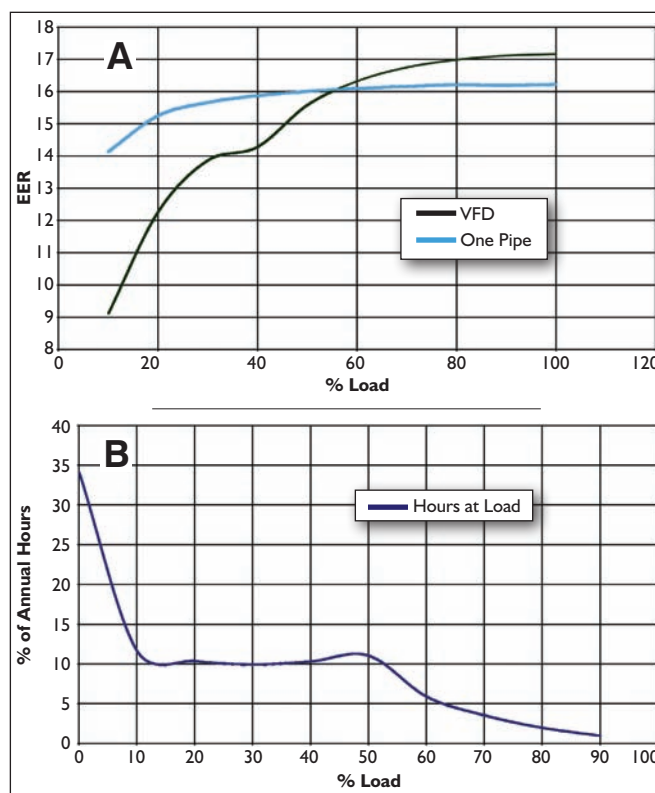

Figure 10a (top): System EER with load comparison. Figure 10b (bottom): System operational comparisons.

loop water temperatures are dwelling between the design maximum and minimum temperature. This phenomenon increases the annual system EER and COP, if the ancillary energy use is proportional with the operating load.

As load is reduced in variable flow systems, flow also is reduced. Water velocity in the ground loop gradually is reduced to a point where it can fall into the transitional or even laminar range. As a result, the overall heat transfer coefficient is reduced, leading to lower heat transfer. Although not an issue affecting peak performance, the effect of the reduced heat transfer is reduced ground coupling of the building through the loop field.

A benefit to one-pipe distribution, though much less amenable to quantification, is the increased heat transfer in the ground loop under off peak conditions. In these systems, the flow rate remains high under all conditions. There are two flow conditions: full flow and a single parallel pump, which is 75% to 80% of full flow. Neither of these flow conditions will result in laminar flow. This leads to favorable temperatures delivered to the heat pumps under all conditions. Under peak conditions, there appears to be no quantifiable difference between the one-pipe and two-pipe variable flow systems, assuming both were sized for the same loop flow rate, heating and cooling loads, and are constructed equally.

Maintainability

To maintain a variable flow system, one must understand the programming and operation of the variable-frequency drive, the control parameters for the pressure control, the operation of the motorized isolation valves, and the operation of the flow control valves. Simplicity is a critical consideration in the school and office building markets, which are the principal markets for GCHP systems.

In a one-pipe system, the flow to the individual units is managed through the unit mounted circulator. The pressure relationship never changes throughout the system, making flow control devices unnecessary.

One-pipe systems use parallel central pumping, there is a back-up pump in position, which is operational at all times. History has shown that a single pump (supplying 75% to 80% of the design flow) maintains the flow requirements more than 95% of the time. The second pump is only necessary during exceptional load conditions. This redundancy offers clients the ability to operate their systems during a maintenance procedure.

Field-Measured Results

These systems have produced exceptional maintenance and operational histories. Without physical modification to the buildings, one-pipe GCHP systems have placed buildings in the top 10% of all schools in the ENERGY STAR performance measurement program, designated within the climate zone for Illinois.

“We have had no maintenance required on the GCHP systems beyond air filter changes. There were a couple of small circulators that failed during initial start-up. As for anything beyond normal PM activities, there has been no maintenance required in the first three years of operation,” said Jeffrey

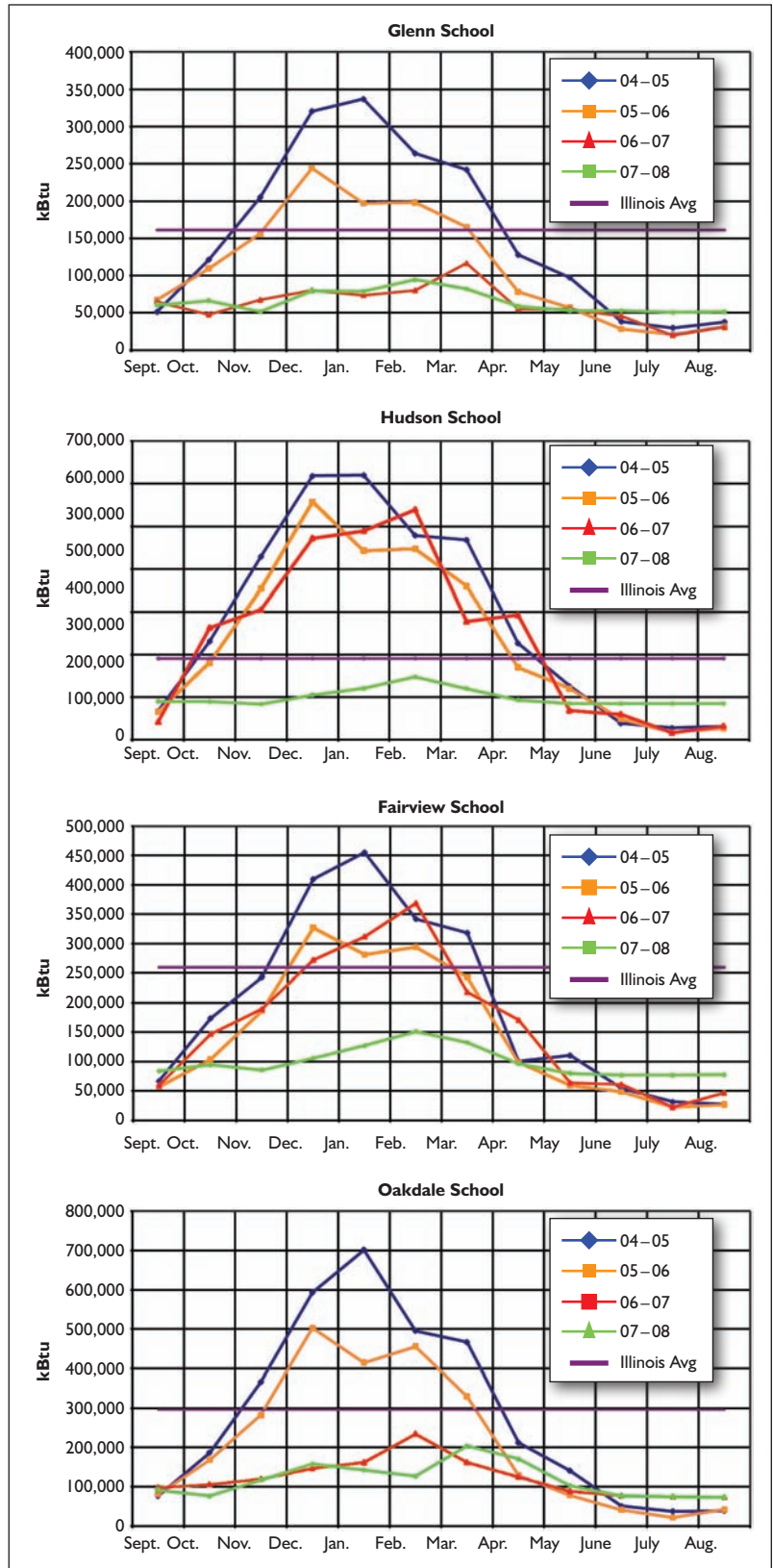

Figure 11: Energy use history of one-pipe schools.

Monohan, director of construction, McLean County Unit, District #5, Normal, Ill. “The results speak for themselves;

five out of the six schools, which have been retrofitted with one-pipe GCHP, have achieved ENERGY STAR ratings in excess of 90. With a little more data, all six schools will achieve the ENERGY STAR minimum of 75,” said Bruce Boswell, energy education officer, McLean County, Unit District #5, Normal, Ill.

Contrary to accepted energy efficiency strategies, using simple controls, which allow occupants the ability to control their environment, has yielded superior results. Educating the occupants so they understand their role in the energy efficiency of their facility yields benefits outside the classroom as well.

Monthly performance for four schools with one-pipe GCHP systems is presented in *Figure 11*. The background curves are two or three years of previous energy meter data, which includes gas and electric for all energy use (including lighting and process) and is normalized on a kBtu basis. The flatter curves represent total energy performance data for one-pipe GCHP systems.

Conclusion

Although not used until recently, one-pipe building distribution systems offer many advantages to geothermal and heat pump applications. What started out as an exercise in improving

system efficiency through an improved pumping strategy has produced additional benefits, beginning with simple, easy to understand systems with low maintenance, based on operator interviews. The expected first and operating cost benefits have also proven substantial. Specifically, the systems have shown reduced installation cost (typical savings of \$0.50 to \$1.50/ft² [\$5.38 to \$16.15/m²]), and ENERGY STAR ratings in excess of 90.

The results have been promising in the Midwest. It will be interesting to see how one-pipe GCHP systems perform in other applications and geographic regions.

References

1. Kavanaugh, S.P., S.A. McInerney. 2001. “Energy use of pumping options for ground-source heat pump systems.” *ASHRAE Transactions* 107(1):589–599.
2. Kavanaugh, S., K. Rafferty. 1997. *Ground-Source Heat Pumps*. Atlanta: ASHRAE.
3. Gao, X., S.A. McInerney, S.P. Kavanaugh. 2001. “Efficiencies of 11 kW variable speed motor and drive.” *ASHRAE Transactions* 107(2):259–265.
4. Rishel, J. 2003. “How to calculate motor efficiency for variable-speed centrifugal pumps.” *Engineered Systems* (7).
5. Water Furnace Envision Performance. 2008. Manufacturer’s Literature. ●